



# Weststar India Elevators

an iso 9001 : 2015 Certified Co. 

*Your Safety & Comfort Riding ....  
Our Responsibility*

- ➔ BEST QUALITY AND DESIGN
- ➔ LOW ENERGY CONSUMPTION
- ➔ EASY INSTALLATION
- ➔ LOW MAINTENANCE

**24x7 Service**





## Company Introduction

---

Established in the year 2016 at Delhi (India), we "weststar india elevators" are prestigious merchant and provider of a thorough combination of Auto, entryway Elevator, Passenger Lift, Hospital Lift, auto lift, goods lifts and Basket Elevator. In our item go, we offer MS Power Coated, False Ceiling, Flooring Option Stainless Steel, Door, Automatic Door Manual Door, Elevator Controller, Elevator, Elevator Traction Machine Unit, lift lodge, entryways, drives, Cabinet, Elevator Door System, we are assembling in numerous types lift Parts in Office and so forth. Our item range is fabricated by our solid sellers in their top of the line producing unit utilizing the finest quality fundamental parts and other partnered material in entire agreement with universal quality principles, Advance, the offered range is stringently tried on different parameters by their very talented quality controllers utilizing most recent testing instruments and hardware. These items are generally recognized by our customers for their preeminent quality, upgraded toughness, powerful development, and ideal execution, with a specific end goal to meet the expanded necessities of our profitable customers, we likewise give the se items in different determination to them,

We are supported by a solid seller base that empowers us to offer our valuable customers' quality guaranteed a scope of items, We have chosen our sellers on the premise of their market notoriety, industry encounter, money related steadiness, and customer's input. we are further guaranteed by our sellers that the offered items are completely tried on different parameters of value utilizing most recent testing machines, devices, and gear by their very experienced group of value controllers with a specific and goal to convey the faultless range to customers. Our sellers are sponsored by an exceedingly talented group of experts, who attempts committed endeavors to fabricate the offered scope of items keeping in mind the end goal to cook our customers' necessity in the most proficient way. The hardware and gear which are introduced in their assembling unit are consistently redesigned in regard to the most recent innovative advancements. Besides, we have likewise ordered our providing group in different divisions like obtainment specialists, quality controllers, deals and advertising workforce and conveyance staff to work easily.

We are upheld with a gigantic and open warehousing office with smooth stock administration framework that is effectively managed by our warehousing workforce. Our warehousing group is prepared in standard warehousing technique and particular strategies to deal with the unambiguous material, This distribution center has been classified into different are as so as to store the items according to their classification. Being a quality driven firm, our prime target is to fulfill our prestigious customers by offering them quality guaranteed items inside the conferred time period. We are a client neighborly firm and have the fundamental concentration to accomplish their most extreme fulfillment. Our solid merchants and a group of experts empower us to convey the offered range to our customers in various determinations and arrangements according to their prerequisites. we additionally consider their profitable input keeping in mind the end goal to enhance our item run.

# Weststar India Elevators





Half Vision Glass Autodoor



S.S. Glass Autodoor



S.S. (304) Center Opening Autodoor



S.S. Center Opening Designer Autodoor



telescopic AutoDoor



Imperferated Manual Door

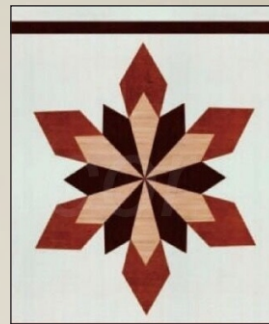

S.S. 304 Designer Sheet Golden/Silver



**EXTERIOS**

- Car cabins
- Wooden car
- Mild steel car-available in powder Coated textured and matt finish
- Stainless steel car-available in hairline, mirror, canvas finish & Multi Designin

**INTERIORS**

- Fall ceiling
- Mild steel fall ceiling
- Stainless steel ceiling
- (Both types can be employed with fan grill and carry CFL fittings)

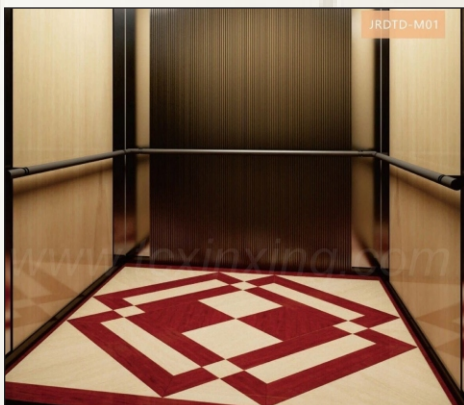

**FLOORING**

- Wooden tile flooring
- Marble, PVC tile flooring
- Granite tile flooring



## **CONTROLLER**

Special Features  
Compact & Space saving Design  
SMD Components  
Optically isolated I/O  
Real time fault logging  
Overload protection

## **ELEVATOR DOOR SYSTEM**

Special Features  
Adjustable door speed at site  
Durable door roller with low noise  
Door de-locking key in Door Frame  
Simple design for faster installation  
Door frame - Integral part of the doors

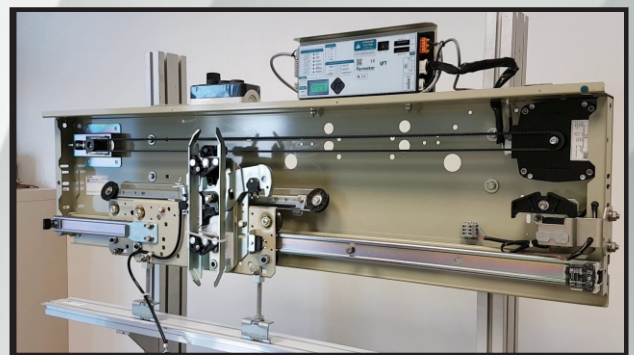

## **ELEVATOR TRACTION MACHINE UNIT**

Special Features  
Highly compact design  
Excellent ride comfort  
V3F speed regulation  
Low energy consumption  
Low maintenance cost  
Hard bronze gear  
Special alloy worm wheel shaft  
Brake-double active DC brake  
Motor-high starting torque with class insulation



# Our Design Lifts



**WIE 01**



**WIE 02**

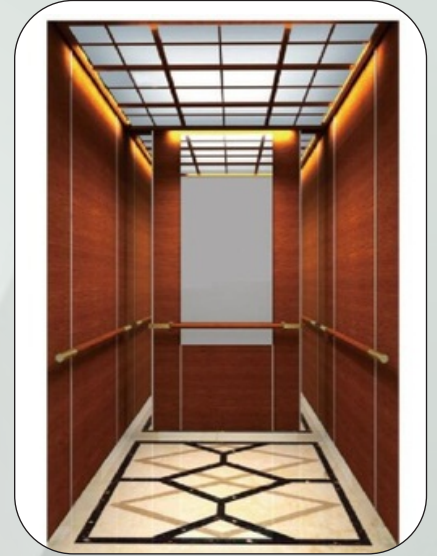

**WIE 03**

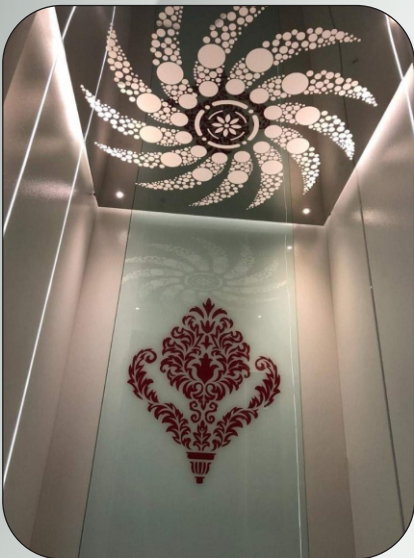

**WIE 04**



**WIE 05**



**WIE 06**



**WIE 07**



**WIE 08**



**WIE 09**



# Our Stockage



**CONTROLLER**



**MOTORS**



**DOOR SENSOR**



**ARD SYSTEM**



**GEARLESS MOTOR**



**USHA MARTIN ROPE**

**(etc.)**



# Our Design Lifts



**WIE-001**



**WIE-002**

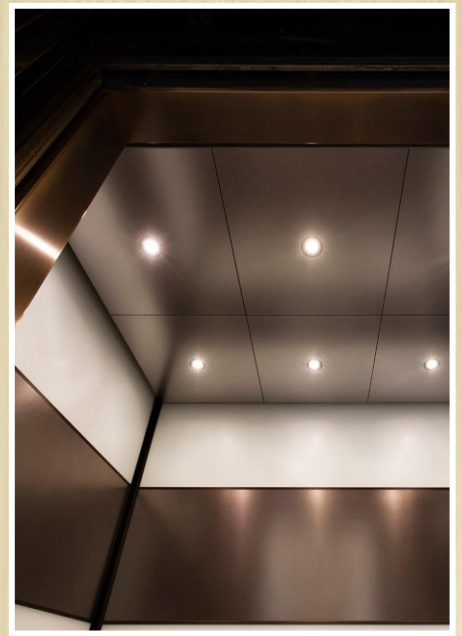

**WIE-003**



**WIE-004**



**WIE-005**



**WIE-006**



# MACHINE ROOM LESS LIFTS

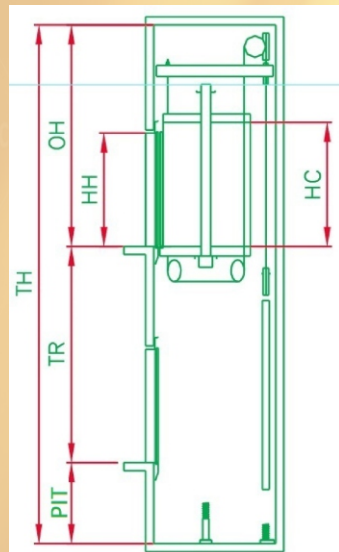
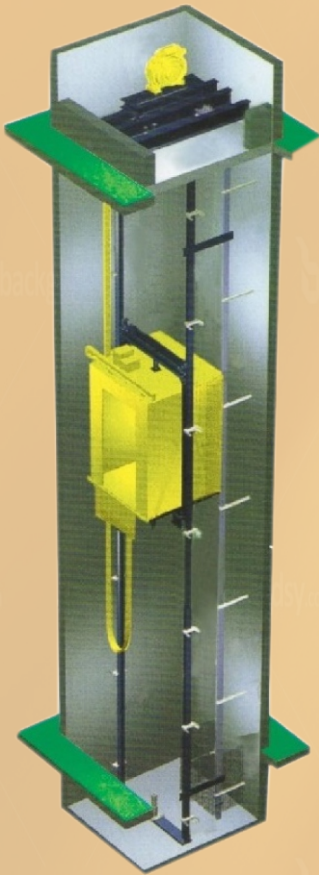

EML-P  
Machine Room Less  
Passenger Elevator

If you're looking for a space-saving MRL elevator that cost less to install and less maintain, There's just one place to visit

- Advantage of MRL Lift
- Improves Aesthetic view of the building
- Additional Saleable space for Builder
- Construction cost-saving (civil & Electrical)
- Greater Saving with V3f Drive
- More comfortable rides
- Improve levelling
- Emergency upto terrace floor
- Introduces new design for new century

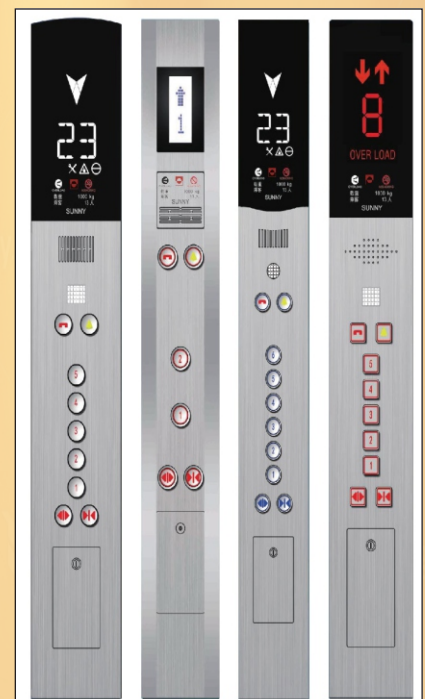

*Weststar India Elevators*



# Sheets Collection



## Classic Stainless Finishes

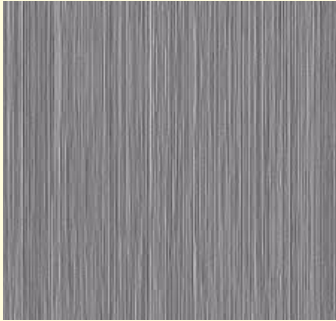

Hairline



Marine



GOLDEN SHEETS

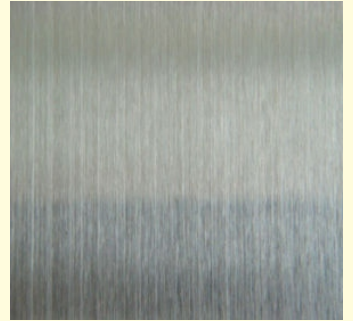

SILVER METTLE SHEETS

## Classic Laminate & Formica Finishes \*

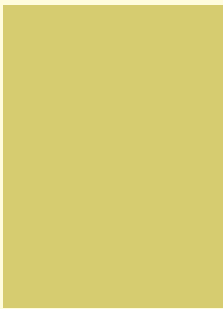

7024



0905

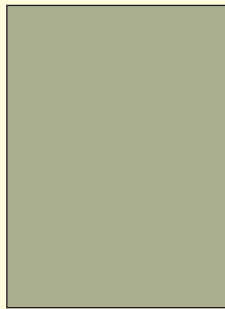

0925



Formica Color Finish -  
Blue



Formica Color Finish -  
Red

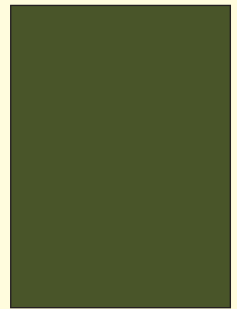

Formica Color Finish -  
Yellow



Fall Ceiling

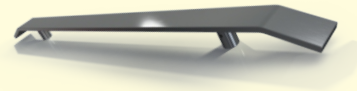

Handrail 1



Handrail 2

## Flat Stainless Steel with/ LED downlings Suspended Ceiling



FH-01



FH-02

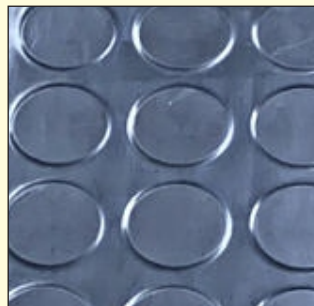

KT-002(PVC)

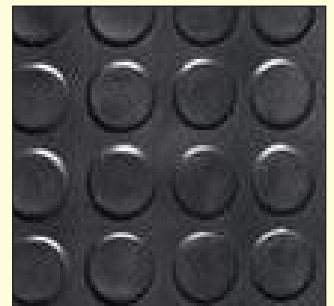

KT-003(PVC)

*Weststar India Elevators*

# ELECTRICAL WORK DONE BY CLIENT



1. FOR PASSENGER LIFT LOAD APP. H.P, (K W 30,415V,50C/S,230V.50C/S).
2. HOIST WAY WIRING WIDTH SWITCH BOARD (SINGLE PHASE WING WITH EARTHING ).TO BE PROVIDED ON SITE OF SW. BOARD AT LEVEL AND ONE AT 1500 MM DOWN TO THE BOTTOM OF TOP FLOOR OF THE LIFT SHAFT.
3. IN MACHINE ROOM 1 TUBE LIGHT, BULB, 1 THREE PIN PLUG POINT & EX, FAN SWITCH TO BE PROVIDED
4. 4 CORE COPPER CABLE 6SQ MM FOR PASSENGER LIFT....H.P. FORM G FLOOR I.C.T.P. SWITCH.
5. 10 GAUGE COPPER WIRE DOUBLE PULLED FROM BY GROUND WITH PROPER TREATMENT.
6. PROPER EARTHING UP TO I.C.D.P. SWITCH IN M/C ROOM TO GROUND FLOOR I.C.T.P. & I.C.D.P. SWITCH

## CIVIL DIMENSIONS/SCHEMATIC DIAGRAM

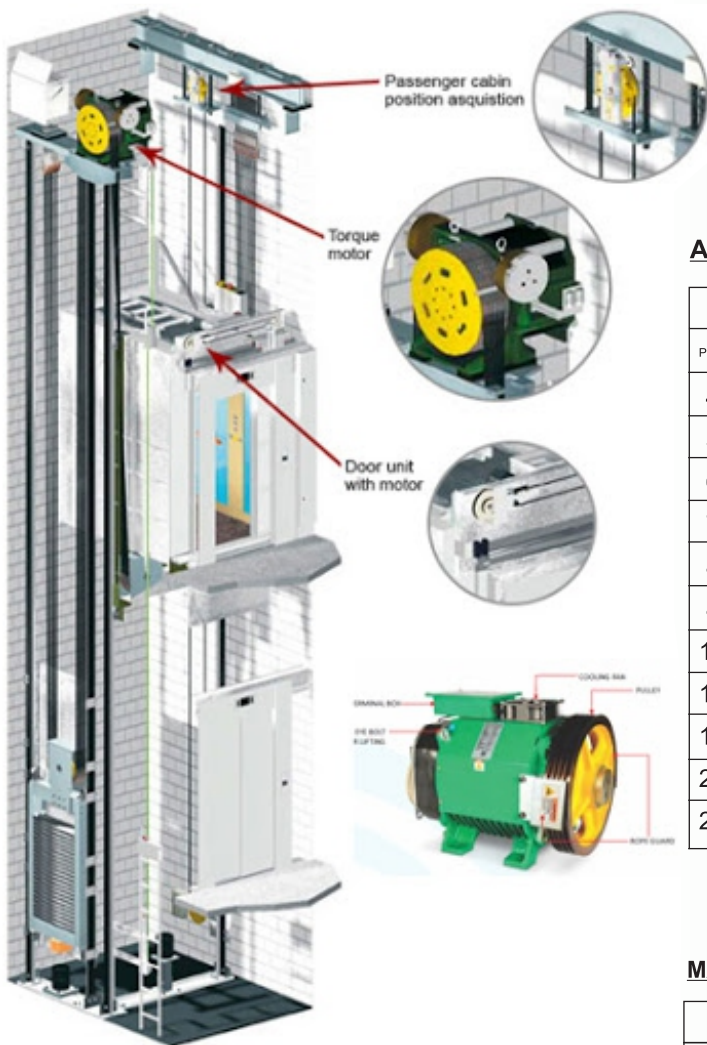

Speed (MPS)	Overhead (OH)	Pit Depth (PIT)
0.50-0.75	4200 mm	1500 mm
1.00	4300 mm	1600 mm
1.50	4800 mm	1600 mm
2.00-2.50	5200 mm	2600 mm

### AUTOMATIC DOOR

Elevator Capacity		Car Inside		Elevator Shaft C/O Door		Elevator Shaft T/O Door		Car Entrance		Machine Room		
Persons	KG	CW	CD	SW	SD	SW	SD	EW	EH	MW	MD	MH
4	272	900	700	1600	1200	1500	1200	700	2000	2400	3000	2400
5	340	900	900	1600	1400	1500	1400	700	2000	2600	3000	2400
6	408	1200	900	1600	1400	1500	1400	700	2000	2600	3000	2400
7	476	1200	1000	1600	1500	1500	1500	700	2000	2600	3000	2400
8	544	1300	1100	1800	1600	1700	1600	800	2000	2800	3675	2700
8	544	1100	1300	1800	1800	1600	1800	800	2000	2900	3675	2700
10	680	1300	1300	1800	1800	1700	1800	800	2000	2850	4000	2700
13	884	2000	1100	2500	1600	2500	1600	900	2000	3500	3850	2700
16	1088	2000	1300	2500	1800	2500	1800	1000	2000	3500	3850	2700
20	1360	2000	1500	2500	2100	2500	2000	1000	2000	3500	4000	2700
26	1768	2400	1800	3000	2400	3000	2300	1200	2000	4000	4000	2700

### MANUAL DOOR

Elevator Capacity		Car Inside		Elevator Shaft		Clear Entrance		Machine Room			
Persons	KG	CW	CD	SW	SD	EW	EH	MW	MD	MH	
4	272	700	800	1250	1250	700	2000	2400	3000	3000	
4	272	800	700	1250	1250	700	2000	2400	3000	2500	
5	340	900	1000	1400	1400	700	2000	2600	3000	2500	
5	340	700	1000	1250	1400	700	2000	2600	3000	2500	
6	408	1200	900	1600	1400	700	2000	2600	3000	2500	
6	408	900	1200	1400	1600	700	2000	2600	3000	2500	
8	544	1300	1100	1800	1600	800	2000	2800	3200	2500	
8	544	1100	1300	1600	1800	800	2000	2800	3200	2500	



# Our Products

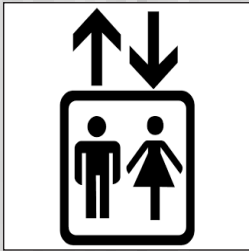

Traction  
Machine Room  
Elevator

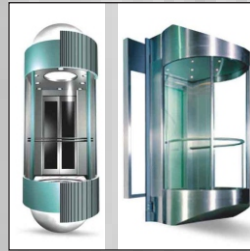

Capsule  
Elevator



Escalator

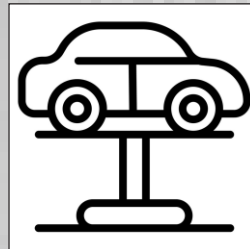

Passenger/Goods  
Hydraulic  
Elevator



Home  
Elevator



MRL  
Gearless  
Elevator

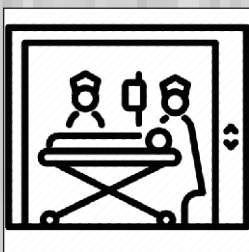

Hospital  
Elevator



Goods  
Elevator

- ➔ Performance
- ➔ Safety
- ➔ Standrds
- ➔ Best Quality

- ➔ Service
- ➔ Space Logic
- ➔ Choice of design
- ➔ Customer Satisfaction

*Weststar India Elevators*



# *Weststar India Elevators*

an iso 9001 : 2015 Certified Co.

## **All Type Elevators Deals :**

### **Regd. Office :**

260-261, IInd Floor, Satyam Tower,  
Paschim Vihar, New Delhi-110063

### **Branch Office :**

Near Police Chowki, Krishna Nager,  
Mathura UP - 281001

### **Contact :**

91+9540996691, 9540996693, 9808851424

### **Office:**

+91 11-41501832

### **Email id & Website**

[www.weststarindiaelevators.com](http://www.weststarindiaelevators.com)

[info@weststarindiaelevators.com](mailto:info@weststarindiaelevators.com)

[jpsaini.xin@gmail.com](mailto:jpsaini.xin@gmail.com)

